

# Cognitive Media Processing #8

---

**Nobuaki Minematsu**



# Title of each lecture

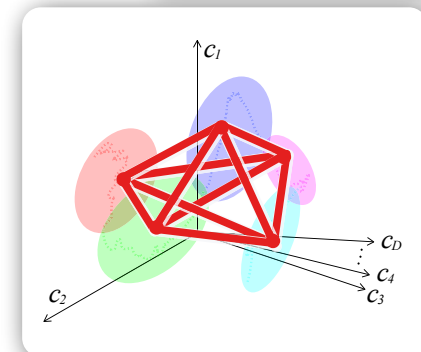

- Theme-1
  - ~~Multimedia information and humans~~
  - ~~Multimedia information and interaction between humans and machines~~
  - ~~Multimedia information used in expressive and emotional processing~~
  - ~~A wonder of sensation - synesthesia -~~
- Theme-2
  - ~~Speech communication technology - articulatory & acoustic phonetics -~~
  - ~~Speech communication technology - speech analysis -~~
  - ~~Speech communication technology - speech recognition -~~
  - **Speech communication technology - speech synthesis -**
- Theme-3
  - A new framework for “human-like” speech machines #1
  - A new framework for “human-like” speech machines #2
  - A new framework for “human-like” speech machines #3
  - A new framework for “human-like” speech machines #4

# Speech Communication Tech.

## - Speech synthesis -

---

**Nobuaki Minematsu**



# Today's menu

---

- Overview of text-to-speech conversion
  - From speaking machine to reading machine
- Text analysis
  - Text processing using units of sentences, phrases, and words
- Reading analysis
  - Assignment of reading (phonetic symbol + prosody) to each phoneme
- Waveform generation
  - Conversion of phonetic symbols + prosody to acoustic waveforms
- Some demos
  - Unit selection synthesis + HMM-based synthesis

# The world oldest speech generator

- Speaking machine (Kempelen 1791)

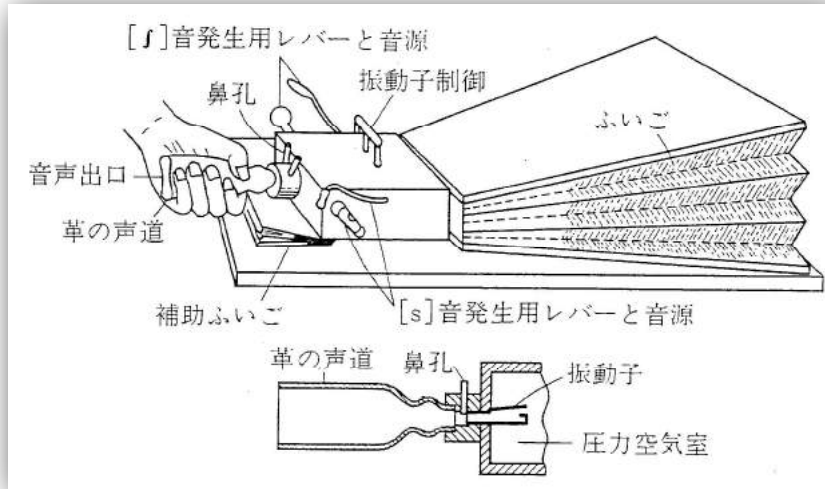

# Difficulty of TTS

---

- Raw text alone is not sufficient “phonetically” for it to be read.
  - How to read Kanji? How to convert Kanji to Hiragana?
    - 今日の午後は、生物学の授業に出ました。
    - 今日=きょう？こんにち？ 生物=せいぶつ？なまもの？
  - Hiragana is similar to phonemic representation. It is enough for TTS?
    - と**ん**ぼ, と**ん**ねる, ど**ん**ぐり
    - **す**いか, たべま**す**か？
  - If text is represented by phonetic symbols, is it enough?
    - How about prosodic features which are needed for text-to-speech conversion?
    - Intonation, word accent, durational control (speaking rate), etc.
    - 赤 (あ**か**) + え**ん**ぴつ → **あ**かえ**ん**ぴつ
  - Only “read”-style speech? Only native speech?
    - Expressive (emotional) speech
    - Non-native speech

# Phones and phonemes

## • Phones

- A phone is the minimal unit of speech of any language.
- Phonetic symbols are **language-independent** and used by phoneticians to transcribe speech of any language. Defined by by Int. Phonetic Association.
- Should be used like [ a b c d e f g ].

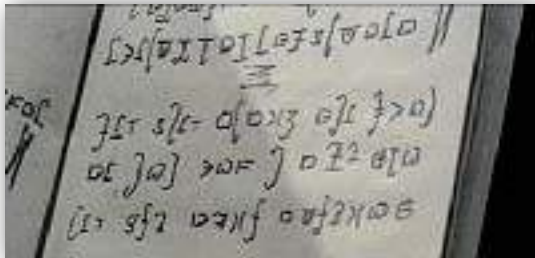

Dental	Alveolar	Postalveolar	Retroflex	
	t	d	t	d
		n		ɳ

## • Phonemes

- A phoneme is the minimal unit of speech of a specific language, perceived by native speakers of that language.
- Phonemic symbols are **language-dependent** and used by ordinary people to transcribe speech of that language. Can be defined by a user.
- Should be used like / a b c d e f g /.

/arajurugeNzituo/ → [ʌrəjɪrɪgɛ̃ɳd͡zɪtsɪoʔ]

# Overview of text-to-speech conversion

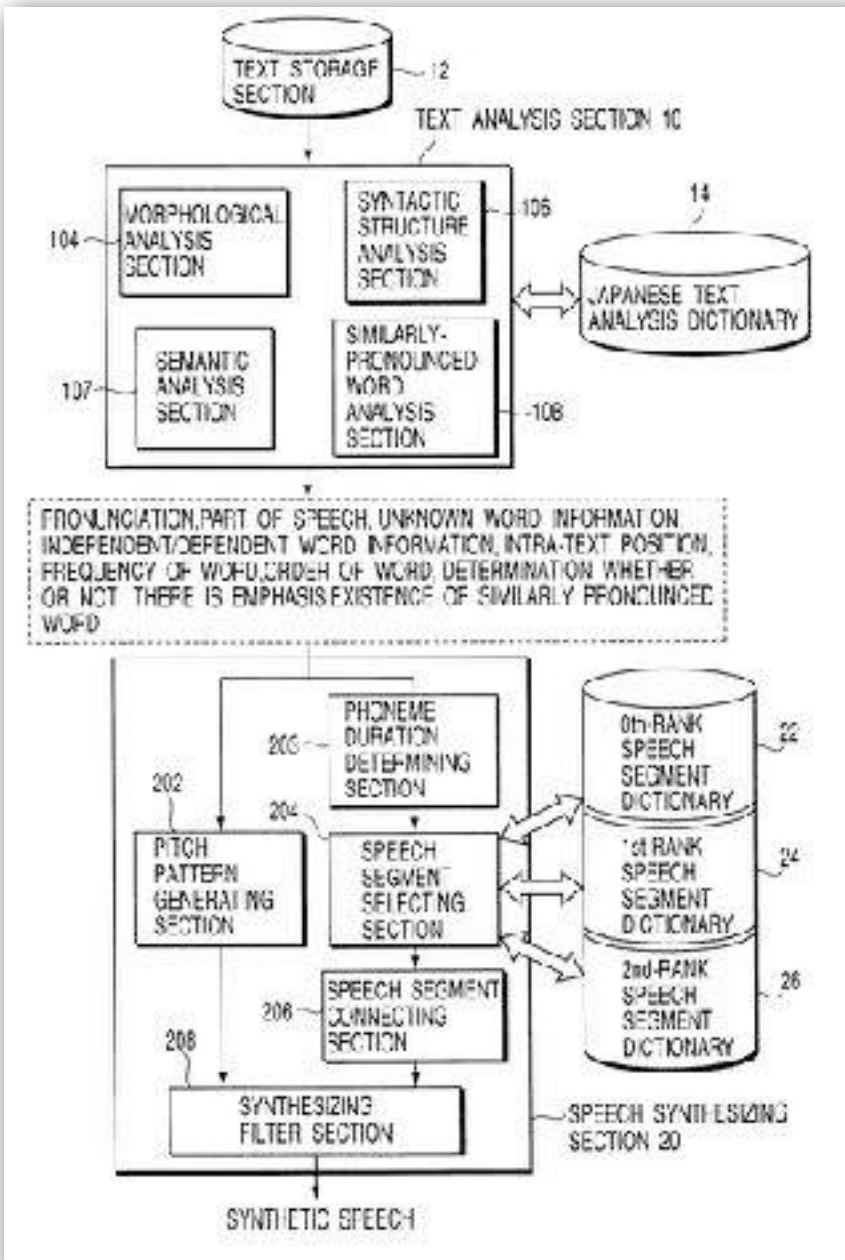

## Conversion of any text input to its reading

今日の午後は、生物学の授業に出ました。

## Conversion of reading to waveforms

今日 = キョー? コンニチ?

生物 = セイブツ? ナマモノ?

キョーノゴゴワ / セイブツガクノジュギョーニ / デマシタ

は = ハ? ワ?

セイブツ + ガク → セイブツガク

Vowel in シ of デマシタ = voiced or unvoiced?



# Text-to-speech synthesis

- Conversion from any input text to its sound sequence
  - In Japanese, Kanji have multiple ways of reading.
  - Kanji, Hiragana, Katakana, and Romaji
- Text analysis
  - Morphological analysis
    - An input sentence is divided into words (morphemes).
    - Part of speech (品詞) is assigned to each word.
  - Syntactic analysis
    - Syntactic structure in a sentence is extracted.
  - Semantic analysis
    - In many cases, it refers to correlation and co-occurrence among words.
- Reading analysis
  - Phonemic aspect
  - Prosodic aspect
- Waveform generation

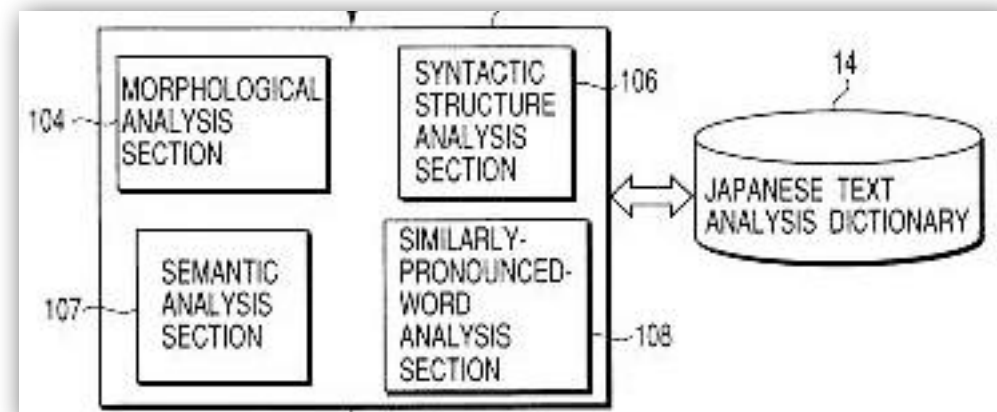
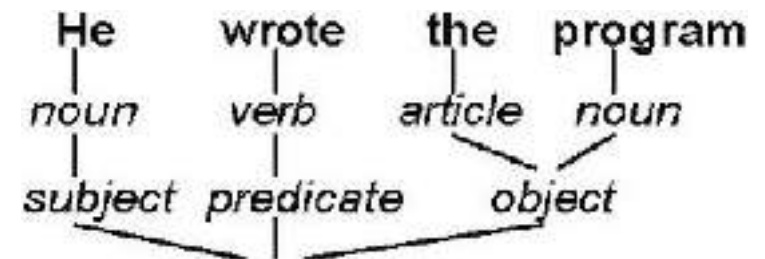

# Reading analysis

---

- Phonemic aspect (segmental aspect of speech)
  - Text to phonemic (Hiragana) representation
    - 今日の午後は → ky o: n o g o g o w a (きょうのごごは)
  - Phonemic representation to phonetic representation
    - ん(N) → n, m, ng ?
    - Some vowels have to be unvoiced.
    - :
- Prosodic aspect (supra-segmental aspect of speech)
  - Word-level processing
    - Word accent, accent sandhi in compound words
  - Phrase-level processing
    - Accent sandhi in connected words of a phrase
  - Sentence-level processing
    - Emphasis, phrasing

# Raw text to Hiragana (phonemes)

---

- Two different reading styles of Japanese
  - On(音/オン)-reading and Kun(訓/くん)-reading
    - 生きる (い) , 生える (は) , 生物 (セイ, なま) ,
- は and へ
  - は in 私は : “w a”, not “h a”
  - へ in 大学へ : “e” not “h e”
- Lengthened vowels
  - 消耗 (しょうもう) : sh o: m o:
  - 映画 (えいが) : e: g a
  - 大阪 (おおさか) : o: sa ka
- Geminate consonant sounds (especially in numerical expressions)
  - 一巻 (いっかん, ikkan) k becomes long (long consonant).
- Euphonic change of an unvoiced consonant to its voiced version (連濁)
  - 江戸川 (えど+かわ→えどがわ)

# Numerical expressions

---

- Two different ways of reading numerical expressions
  - 03-5841-6662 : digit by digit
  - 123,456 yen : use of places, e.g. 12万3千4百5十6円
- Sound changes that are unique to numerical expressions
  - 523 is not ご に さん but ごおにいさん
- Geminate consonant sounds
  - 一本 : いち + ほん → いっほん
  - 1 cm : いち + せんち → いっせんち
- Euphonic change of unvoiced consonant to its voiced version (連濁)
  - 三本 : さん + ほん → さんぼん
  - 三階 : さん + かい → さんがい
  - 三回 : さん + かい → さんかい
- Exceptional cases
  - 一日 : ついたち (いちにち is OK)
  - 二日 : ふつか (ににち is OK)

# Phoneme symbols to phonetic symbols

---

- Some vowels become unvoiced
  - If a vowel is surrounded by unvoiced consonants, it often become unvoiced.
    - アシカ (a sh **i** k a) , エンピツ (e N p **i** t s u) , スキヤキ (s **u** k i y a k i) etc
- Nasalized consonants
  - 株式会社 (かぶしきがいしゃ, k a b u s h i k i **g** a i s h a)
- Syllabic nasal (撥音, ん)
  - 粘板岩 (ね**ん**ば**ん**が**ん**)
    - [m] before p, b, and m
    - [ng] before k, g, and ng
    - [n] before t, d, n, and pause

# Non-linguistic symbols and short forms

---

- Have to be converted into their phoneme sequences
  - %, kg, @
  - HMM, IT, IEEE
- Unknown words
  - Person's names, city names (proper nouns)
  - Their reading have to be predicted using linguistic knowledge.
    - Grapheme-to-phoneme conversion

# Reading analysis

---

- Phonemic aspect (segmental aspect of speech)
  - Text to phonemic (Hiragana) representation
    - 今日の午後は → ky o: n o g o g o w a
  - Phonemic representation to phonetic representation
    - ん(N) → n, m, ng ?
    - Some vowels have to be unvoiced.
    - :
- Prosodic aspect (supra-segmental aspect of speech)
  - Word-level processing
    - Word accent, accent sandhi in compound words
  - Phrase-level processing
    - Accent sandhi in connected words of a phrase
  - Sentence-level processing
    - Emphasis, phrasing

# JEITA format

- Japan Electronics and Information Technology Industries Association
  - Text format designed specially for TTS input.
  - Proposed as standard and recommended by JEITA
  - Examples
    - 2006年の調査によると、日本全国で、約33%の家庭が、ペットを飼っているそうです。
    - ニセンロクネンノチョウサニヨルト、ニホンゼンコクデ、ヤクサンジュウサンパーセントノカテイガ、ペットヲカッテイルソウデス。
    - **ニセ'ンロクネンノ/チヨ'ーサニヨルト\_ニホ'ン\_ゼ'ンコクデ\_ヤ'ク/サ'ンジューサンパーセ  
ントノカテーガ\_ペ'ットオ/カ'ッテイルソーデス%.**
    - ペットを家族のように考える人が増えたため、ペット関連の新しいビジネスも、生まれました。
    - ペットヲカゾクノヨウニカンガエルヒトガフエタタメ、ペットカンレンノアタラシイビジ  
ネスモ、ウマレマシタ。
    - **ペ'ットオ/カ'ゾクノヨーニカンガエルヒ%トガ\_フ'エタタメ\_ペットカンレンノ\_アタラシ  
'ー/ビ'ジネスモウマレマシ%タ.**



# Text-to-speech synthesis

- Conversion from any input text to its sound sequence
  - In Japanese, multiple ways of reading have to be dealt with.
  - Kanji, Hiragana, Katakana, and Romaji
- Text analysis
  - Morphological analysis
    - An input sentence is divided into words (morphemes)
    - Part of speech (品詞) is assigned to each word.
  - Syntactic analysis
    - Syntactic structure in a sentence is extracted.
  - Semantic analysis
    - In many cases, it refers to correlation analysis of
    - words that occur frequently.
- Reading analysis
  - Phonemic aspect
  - Prosodic aspect
- Waveform generation

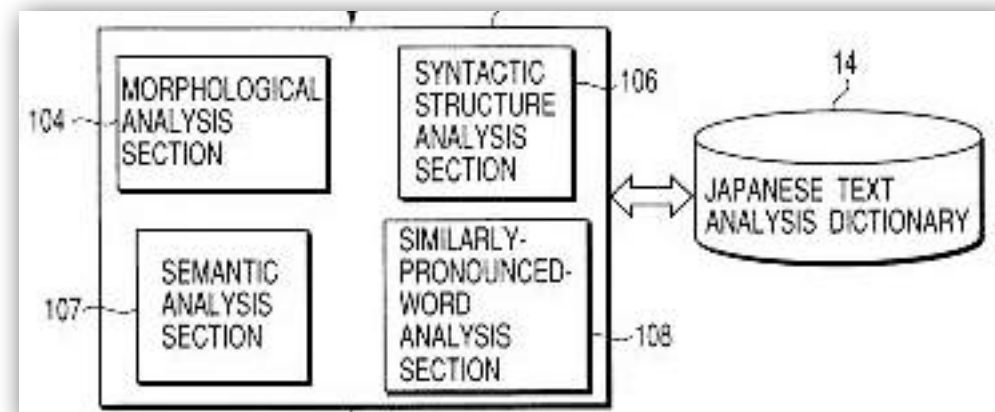
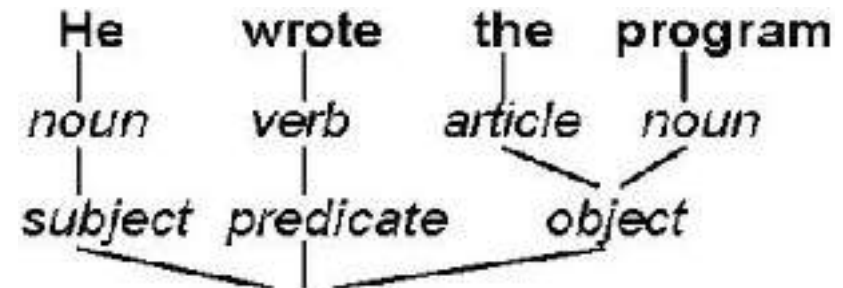

# Two major methods of waveform generation

---

- Unit selection synthesis
  - A huge number of **waveform** units (templates) are stored in a database.
  - Adequate selection of waveform units is done based on input text.
  - The selected units are smoothly concatenated.
  - Additional pitch modification is often needed.
- HMM-based synthesis
  - A kind of “unit selection” synthesis
    - Units are **not waveform units but spectrum units**
  - A huge number of context-dependent phoneme HMMs are stored in a database.
  - Adequate selection of HMMs is done based on input text.
  - The selected HMMs are concatenated.
  - Pitch is realized by generating a source signals based on the desired pitch pattern.

# A diagram of unit selection synthesis

## Unit-selection synthesis (USS) (1)

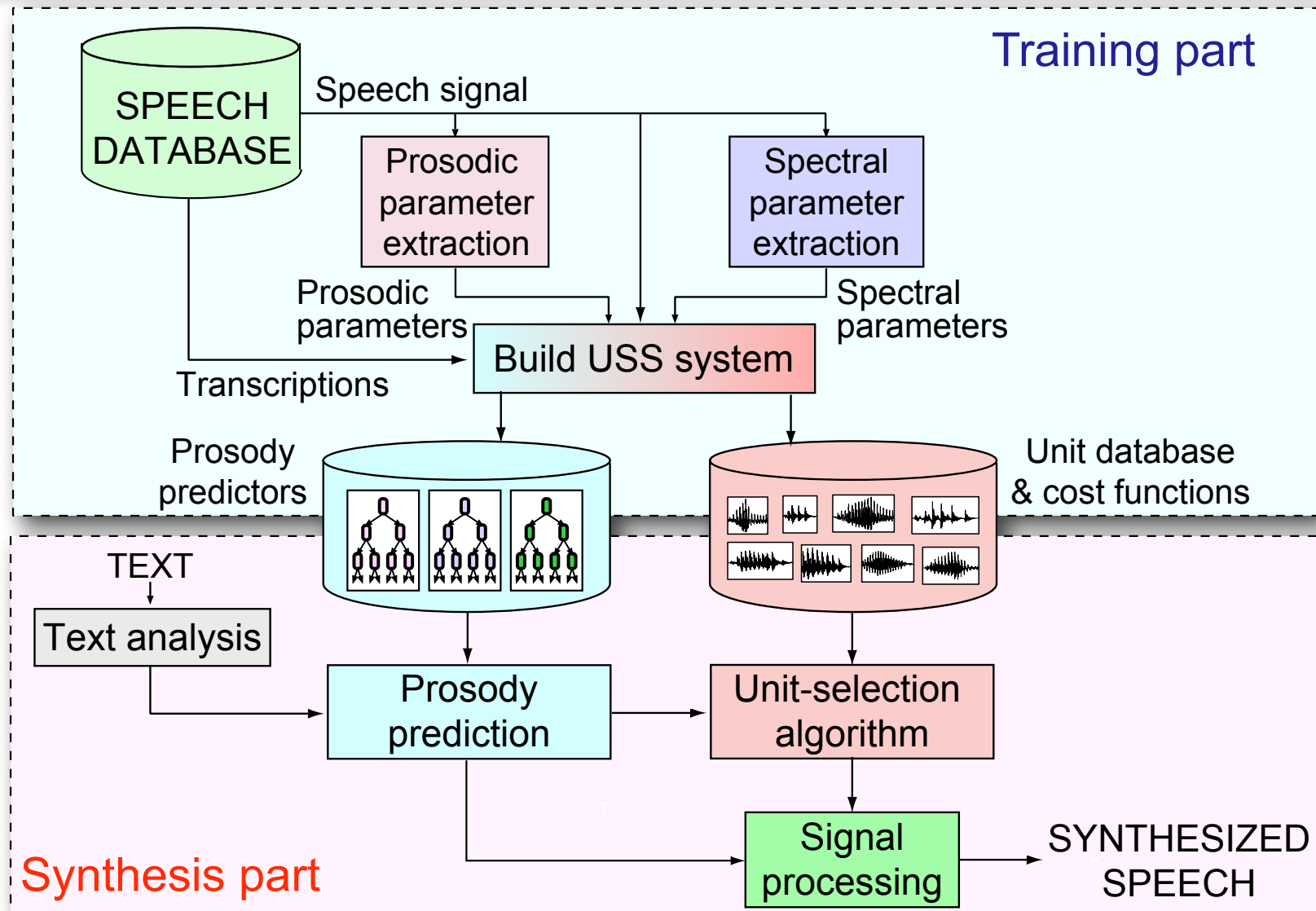

# Unit selection synthesis

- A speech corpus is segmented using some linguistic units.
  - Phoneme, syllable, or in-between?
- Adequate selection of waveform units is done based on text input.
  - How to select adequate units?
- The selected units are smoothly concatenated.
  - If waveform units of the desired pitch level are not found, how to prepare the units?

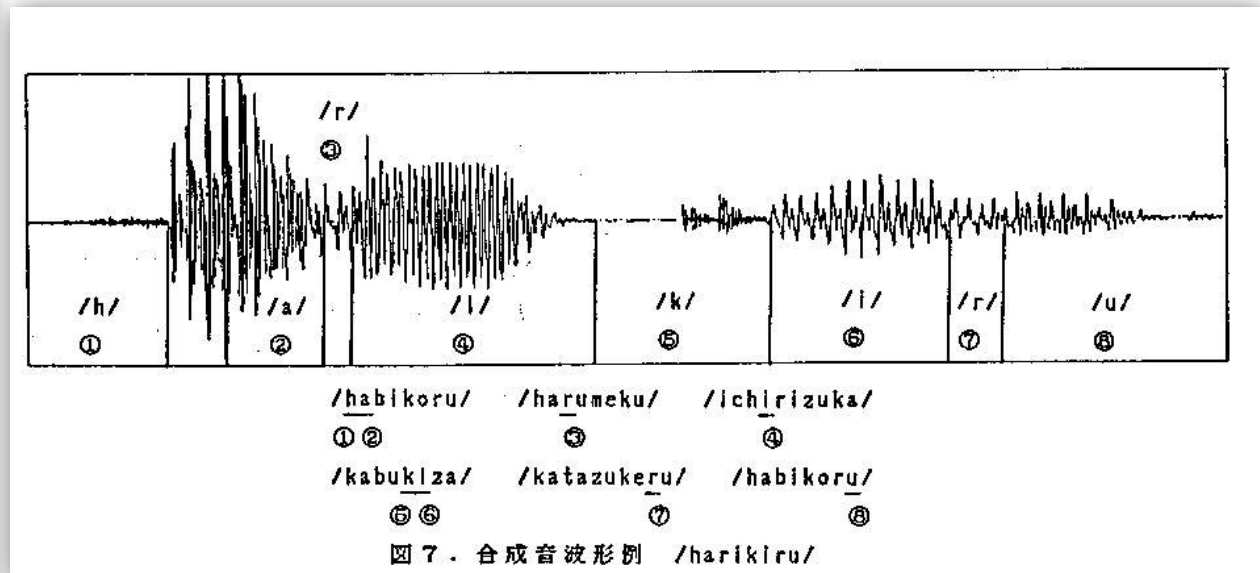
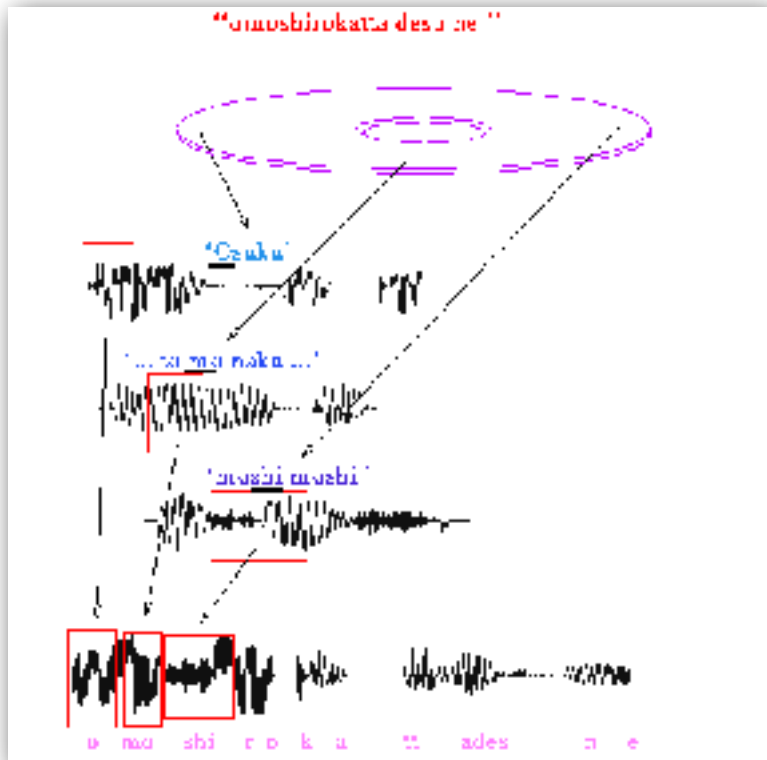

# Unit selection synthesis

- A speech corpus is segmented using some linguistic units.
  - Phoneme, syllable, and VCV units
  - Prosodic attributes are also considered (added) in labeling.

VCV  

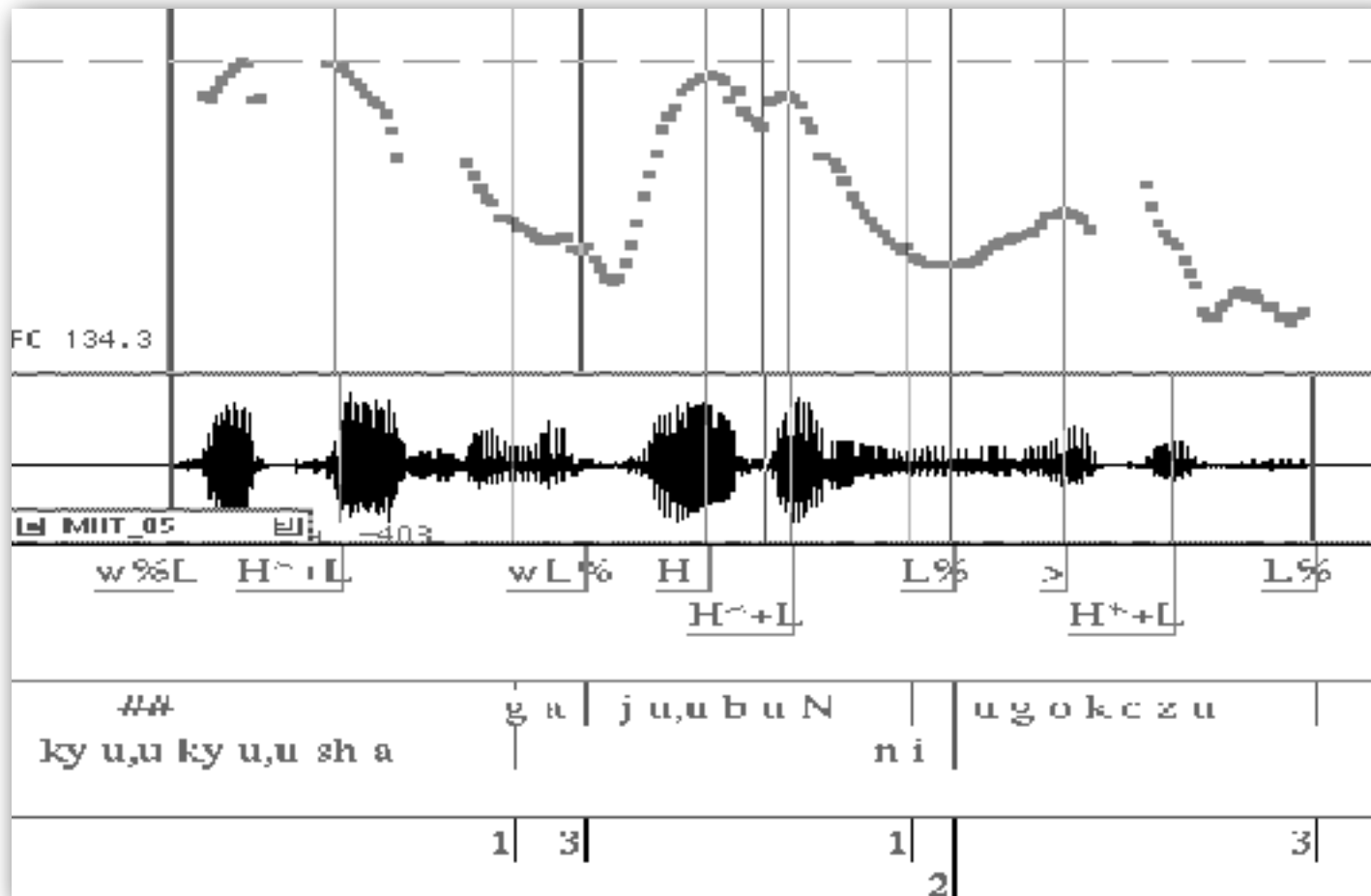

# Unit selection synthesis

- Adequate selection of waveform units is done based on text input.
  - A cost function is defined and the unit that can minimize the cost is selected.

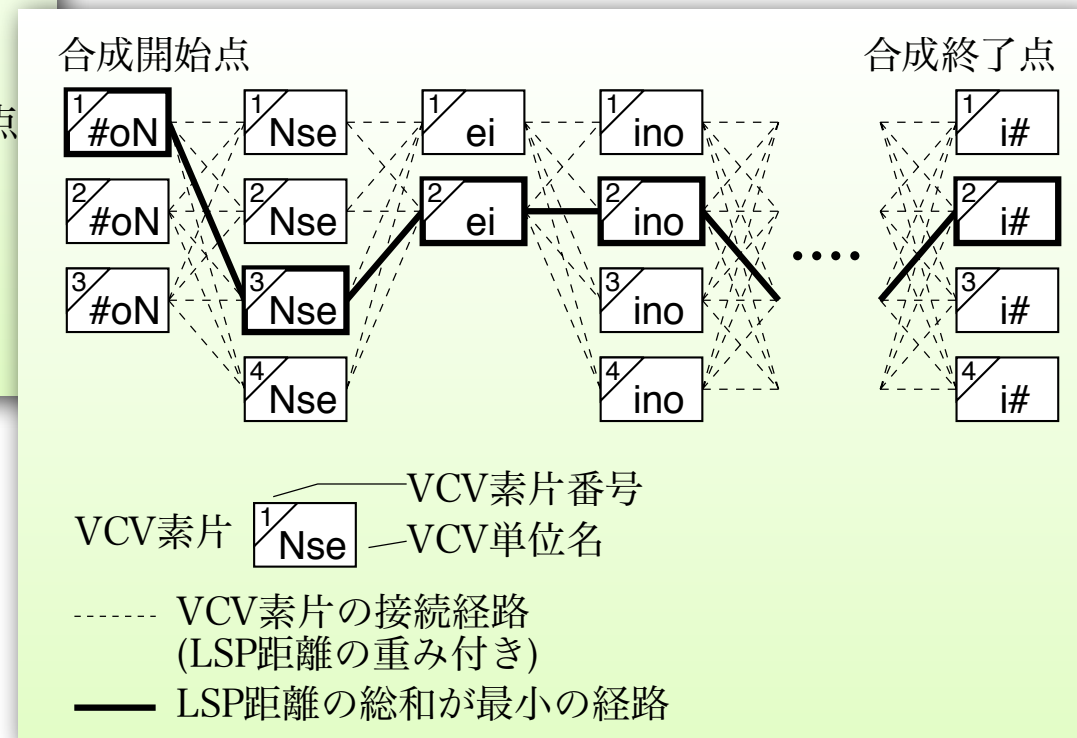
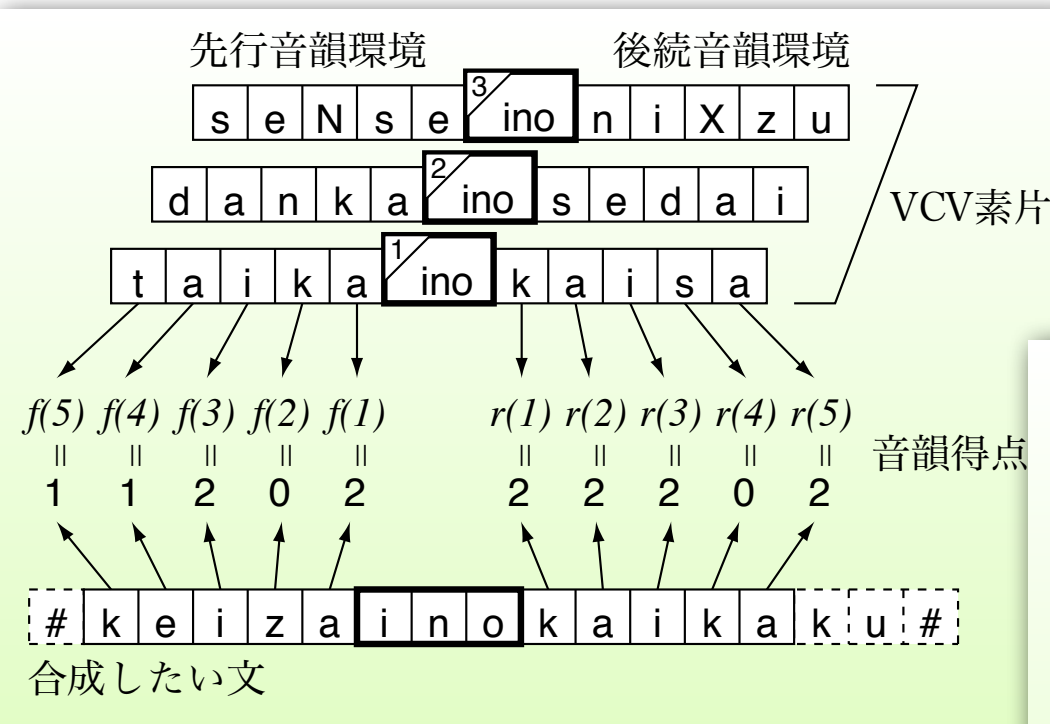

# Unit selection synthesis

- The selected units are smoothly concatenated.
- Pitch change is realized by PSOLA (Pitch Synchronous OverLap and Add)
- Pitch waveforms are concatenated with overlap using required intervals.

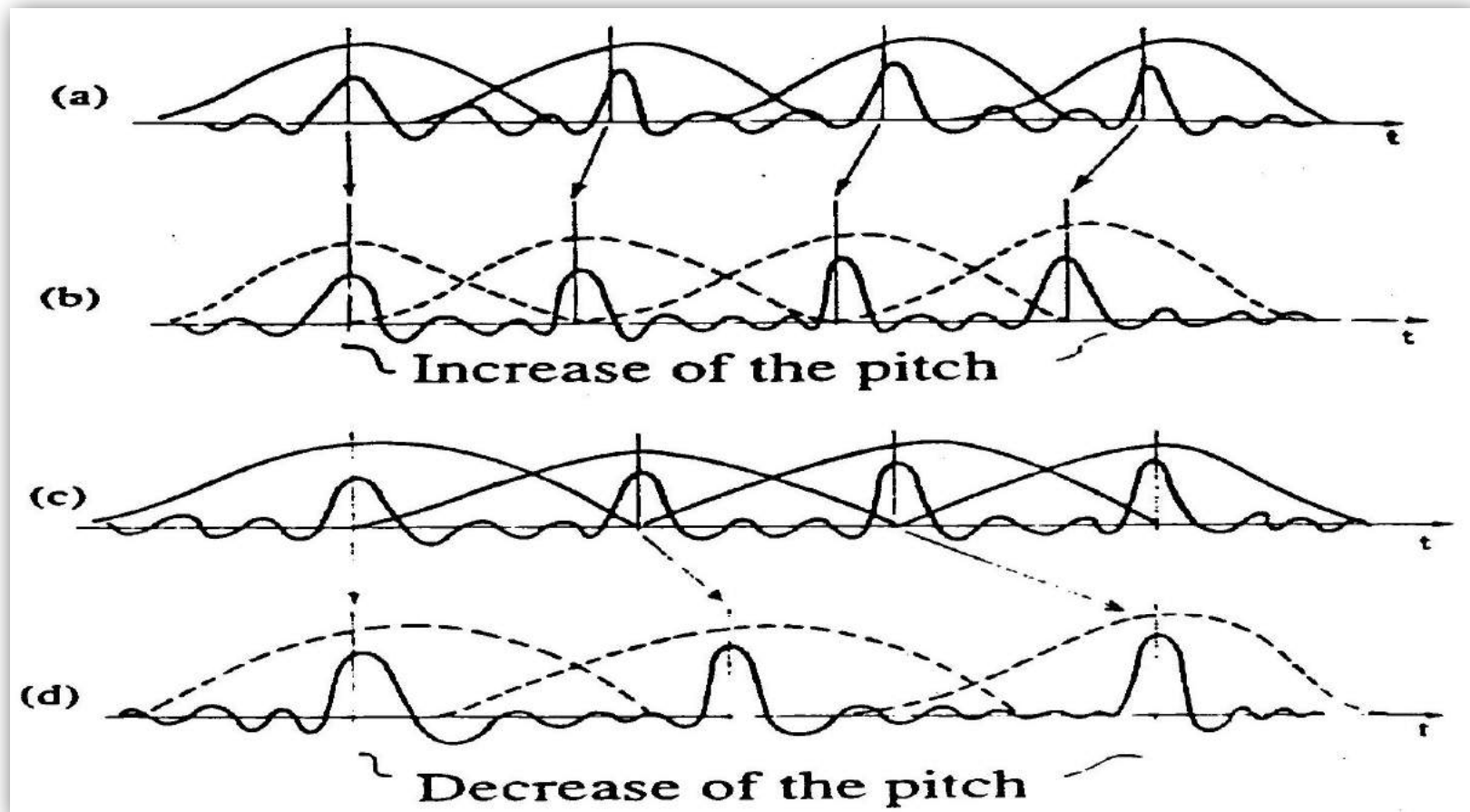

# A diagram of unit selection synthesis

## Unit-selection synthesis (USS) (1)

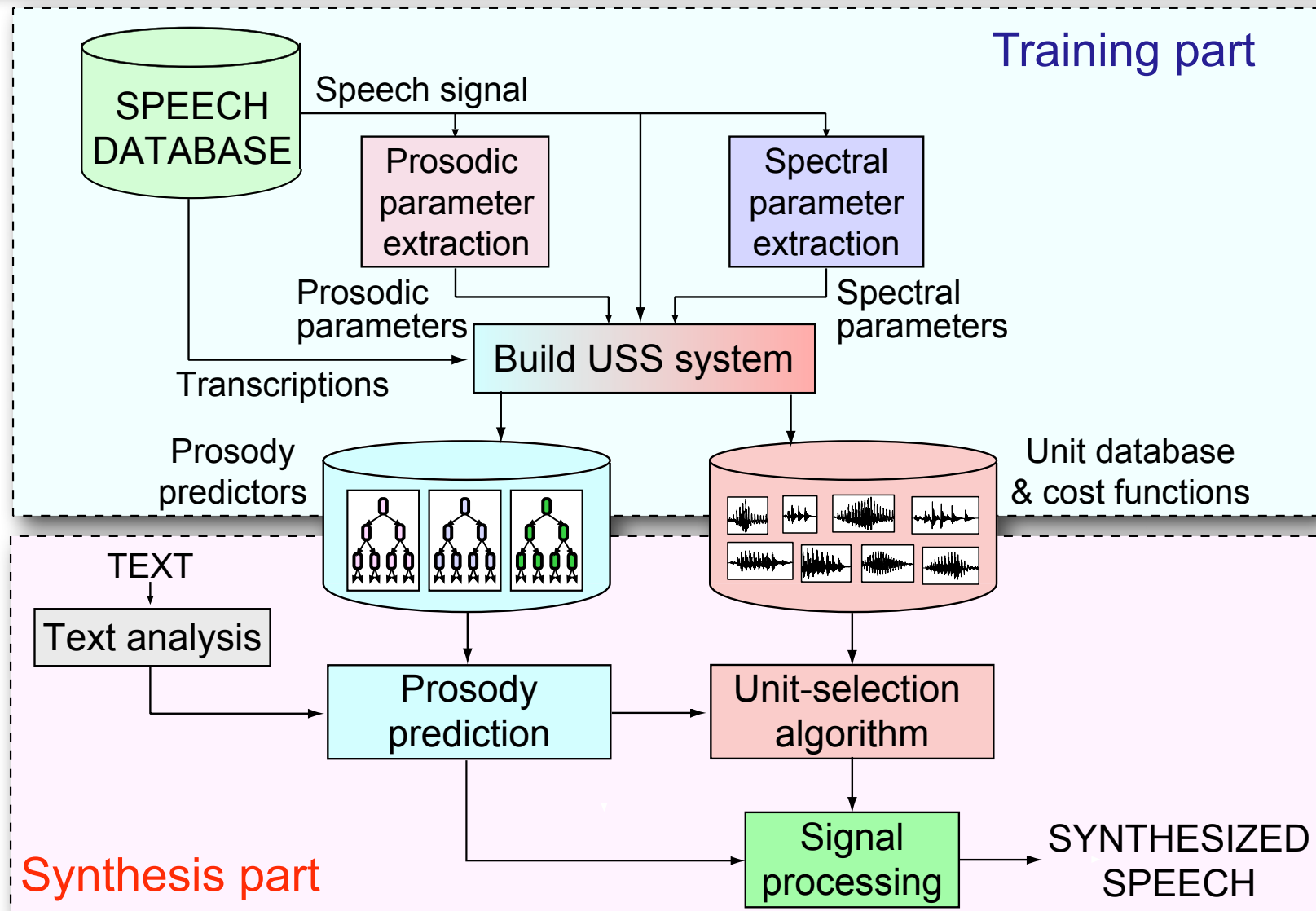



## HMM as generative model

---

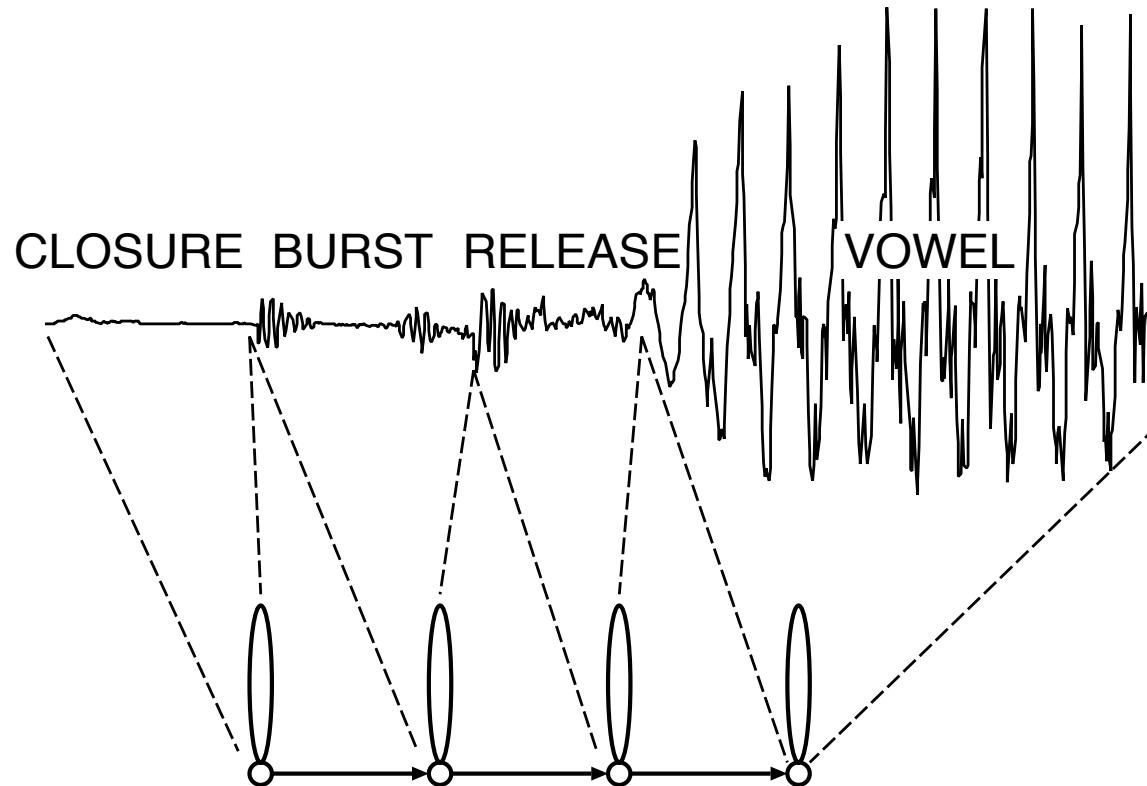

### Probabilistic generative model

State transition is modeled as transition probability.  
Output features are modeled as output probability.

# A diagram of HMM-based synthesis

## HMM-based speech synthesis system (HTS)

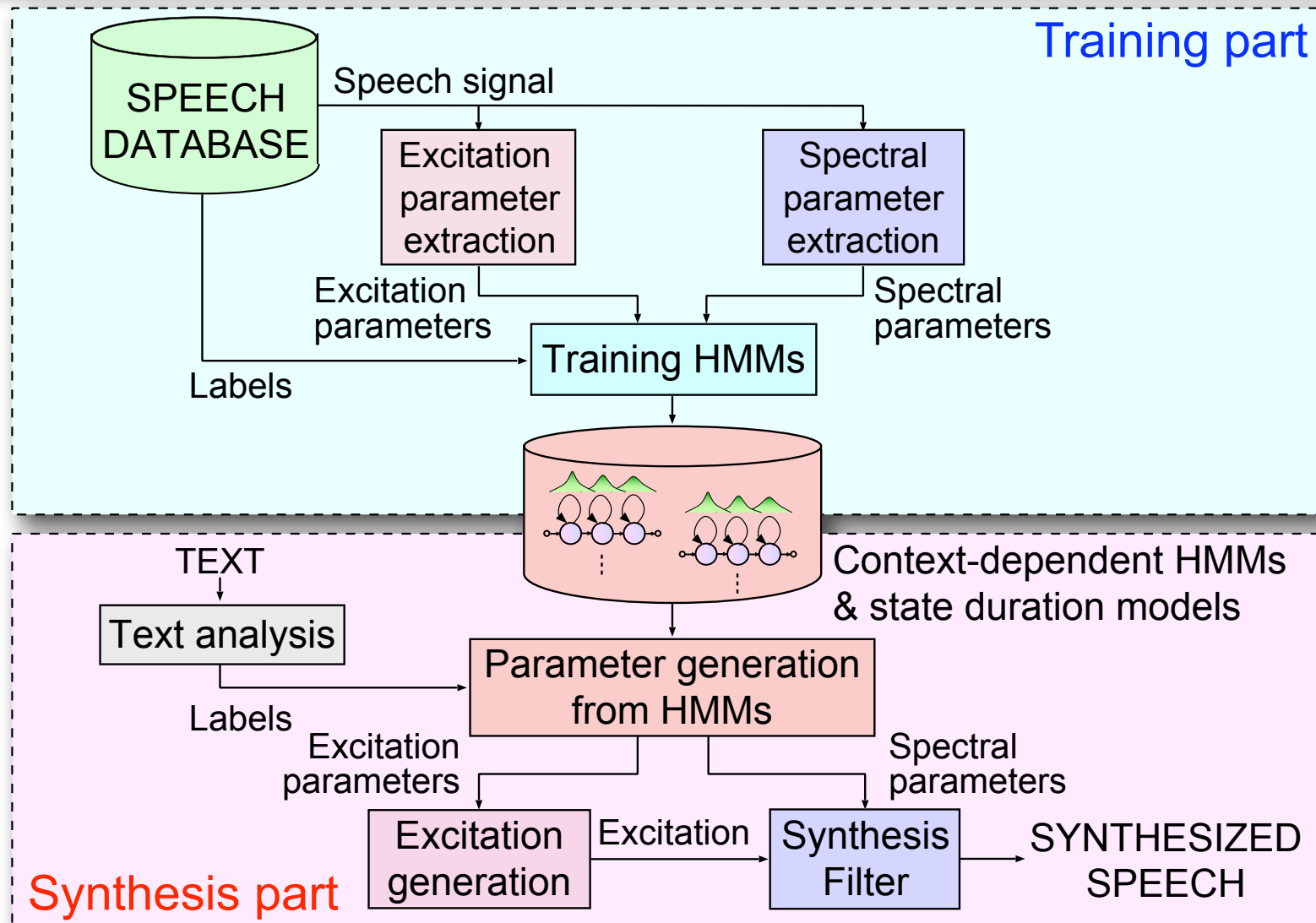

# HMM-based synthesis

- Text  $\rightarrow$  HMM seq.  $\rightarrow$  **most likely state seq.**  $\rightarrow$  **most likely spectrum seq.**
- Spectrum seq. = adaptive filter
- By inputting source signals to the filter, waveforms can be obtained.

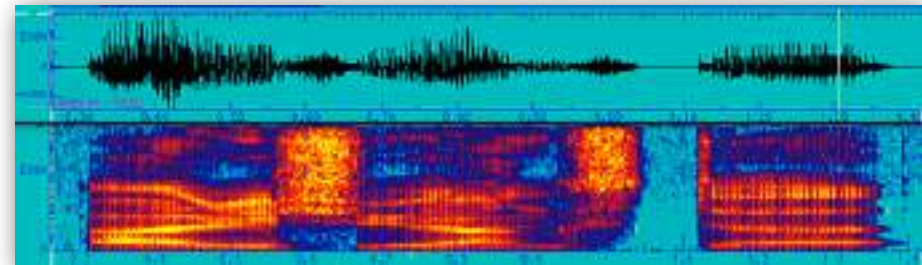
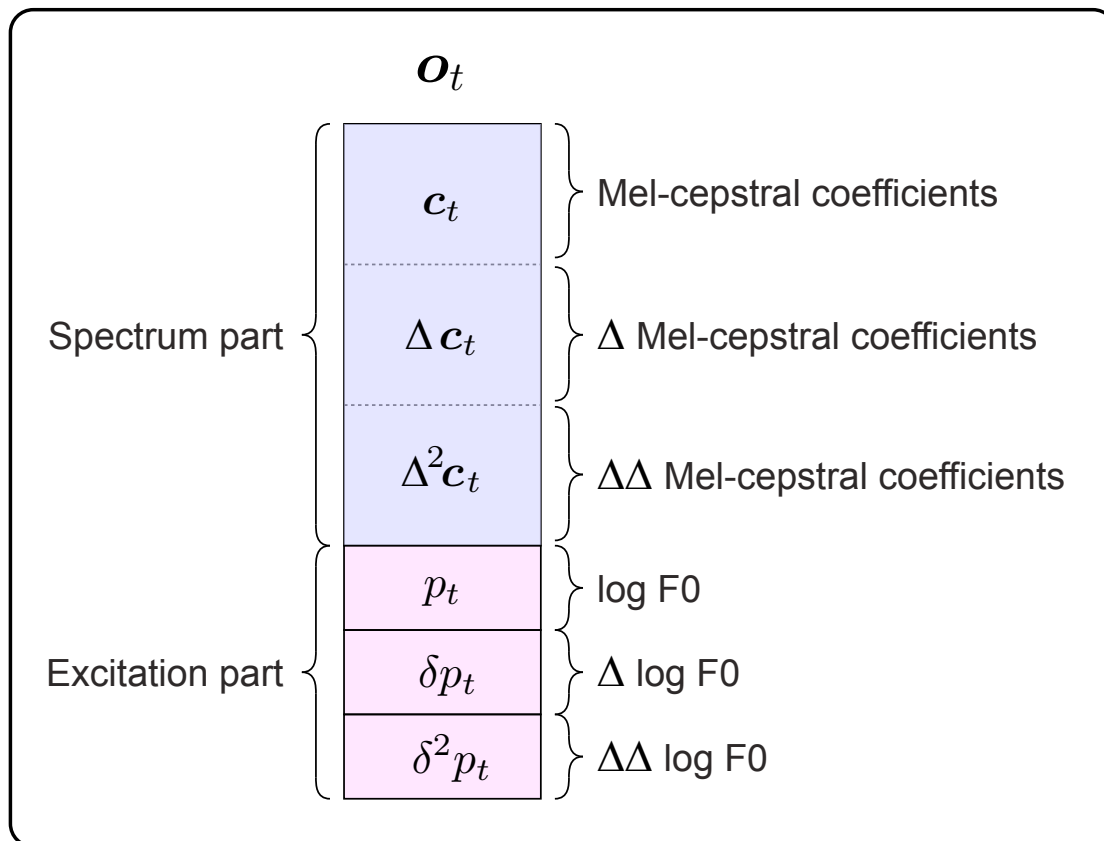

# Spectrum generated from HMMs

- Text -> HMM seq. -> most likely state seq. -> most likely spectrum seq.
- The most likely spectrum from a state = mean vector (spectrum) of the state  
--> the spectrum sequence has to have stepwise abrupt changes.

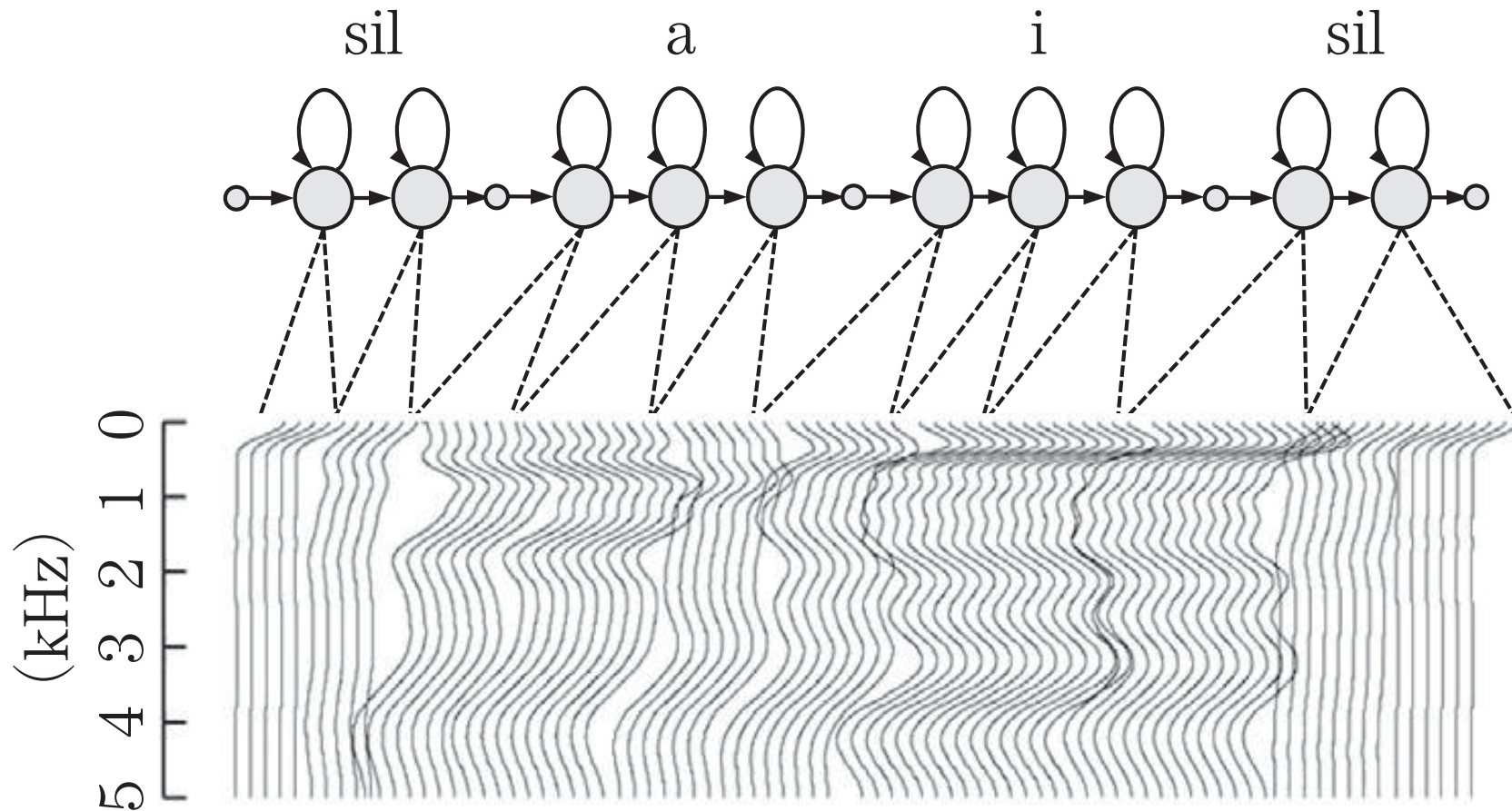

# Spectrum generated from HMMs

- Text -> HMM seq. -> most likely state seq. -> most likely spectrum seq.
- The most likely spectrum from a state = mean vector (spectrum) of the state  
--> the spectrum sequence has to have stepwise abrupt changes.

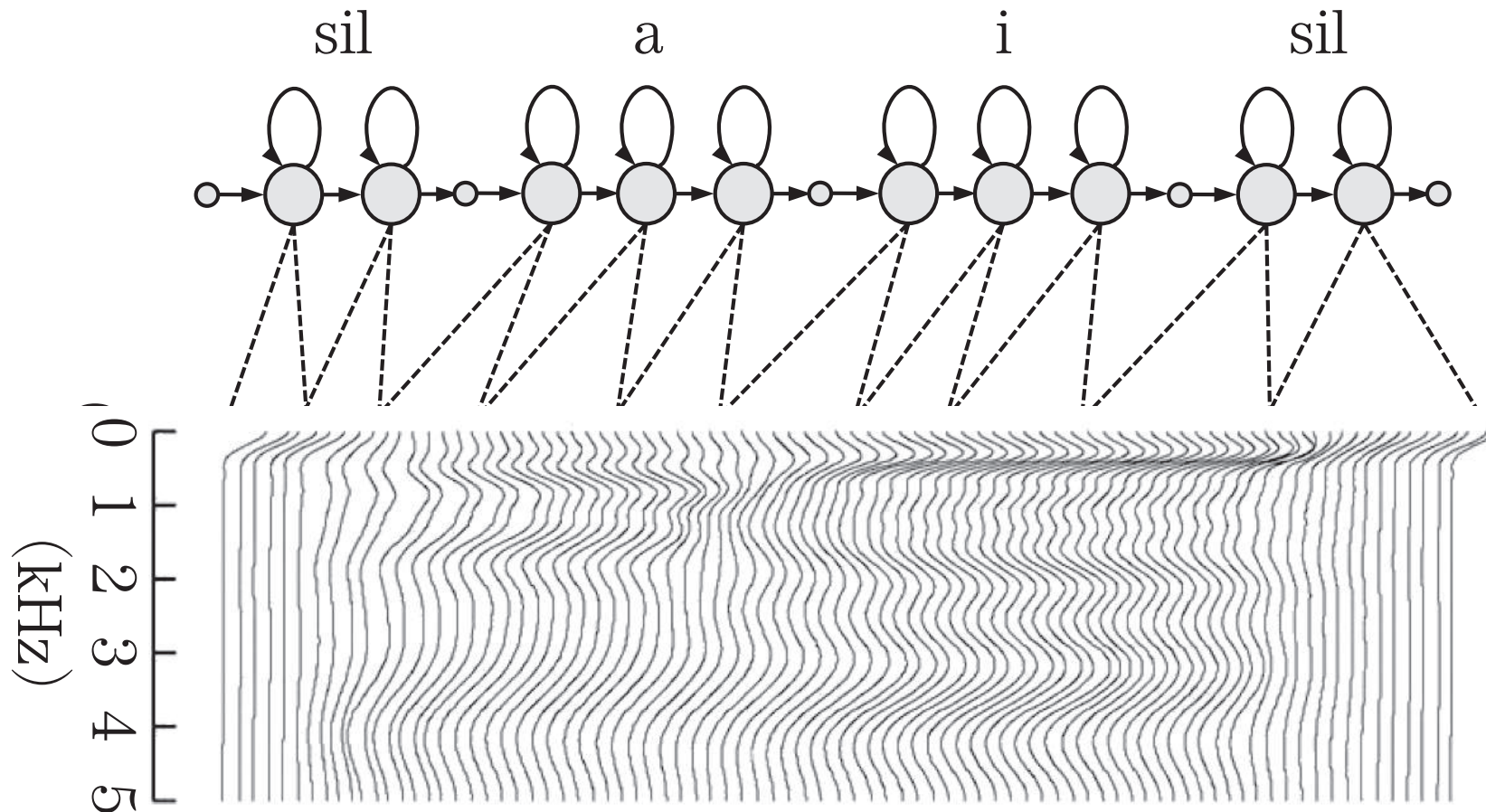



# Static features and dynamic features

- Maximum likelihood generation of Cep sequences **with constraints**
  - $\Delta\text{Cep}$  = velocity components,  $\Delta\Delta\text{Cep}$  = acceleration components
  - $\text{Cep} + \Delta\text{Cep} + \Delta\Delta\text{Cep}$  are used as features of HMM
  - What is needed is a sequence of Cep that is adequate for input text.
    - Cep sequence is generated by using  $\Delta$  and  $\Delta\Delta$  features **as constraint**.
    - Likelihood of  $\Delta\text{Cep} + \Delta\Delta\text{Cep}$  should be increased as well as that of Cep.

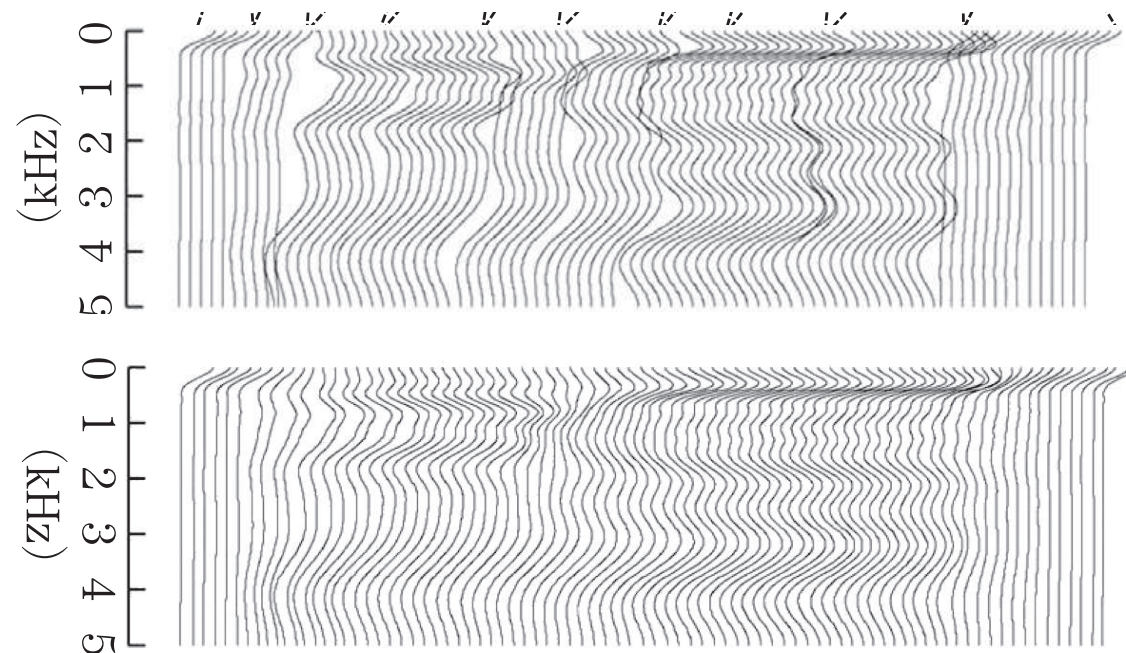
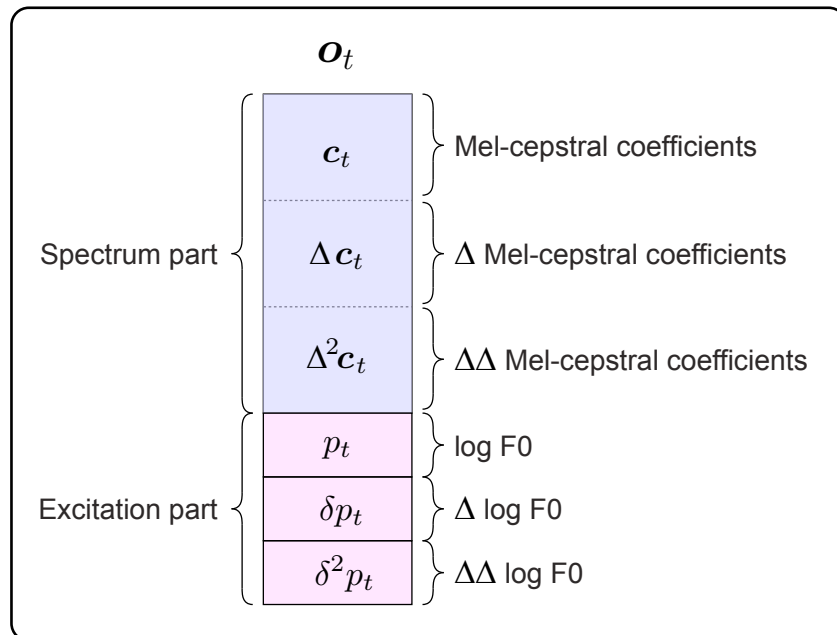

# Context used for HMM for synthesis

- Context-dependent phoneme HMMs for ASR
  - Context = left phoneme and right phoneme
  - /a/ -> i-a+b, u-a+t, h-a+l, ....
  - #triphones =  $N \times N \times N$  (N : number of phonemes)
- Context-dependent phoneme HMMs for TTS
  - Context = left phoneme, right phoneme + so many linguistic factors
  - #context-dependent-phonemes = logically infinite !?
  - HMMs for TTS are by far much finer than HMMs for ASR.

Table 1: Context labels adopted in Japanese HTS

Previous phoneme identity	Connection intensity between the previous accent phrase and the current accent phrase	Number of morae of the previous breath group
Current phoneme identity	Pause existence between the previous accent phrase and the current accent phrase	Number of morae of the current breath group
Next phoneme identity	Number of morae in the current accent phrase	Position of the current breath group in the sentence
Position of the current mora in the current accent phrase	Accent type in the current accent phrase	Number of morae of the next breath group
Difference between accent type and position of the current mora	Connection intensity between the previous accent phrase and the next accent phrase	Number of morae of the sentence
POS of the previous word	Position of the current accent phrase in the current breath group	
Inflected form of the previous word	Interrogative sentence or not	
Conjugation type of the previous word	Number of morae of the next accent phrase	
POS of the current word	Accent type of the next accent phrase	
Inflected form of the current word	Connection intensity between the next accent phrase and the current accent phrase	
Conjugation type of the current word	Pause existence between the next accent phrase and the current accent phrase	
POS of the next word		
Inflected form of the next word		
Conjugation type of the next word		
Number of morae of the previous accent phrase		
Accent type of the previous accent phrase		

# A diagram of HMM-based synthesis

## HMM-based speech synthesis system (HTS)

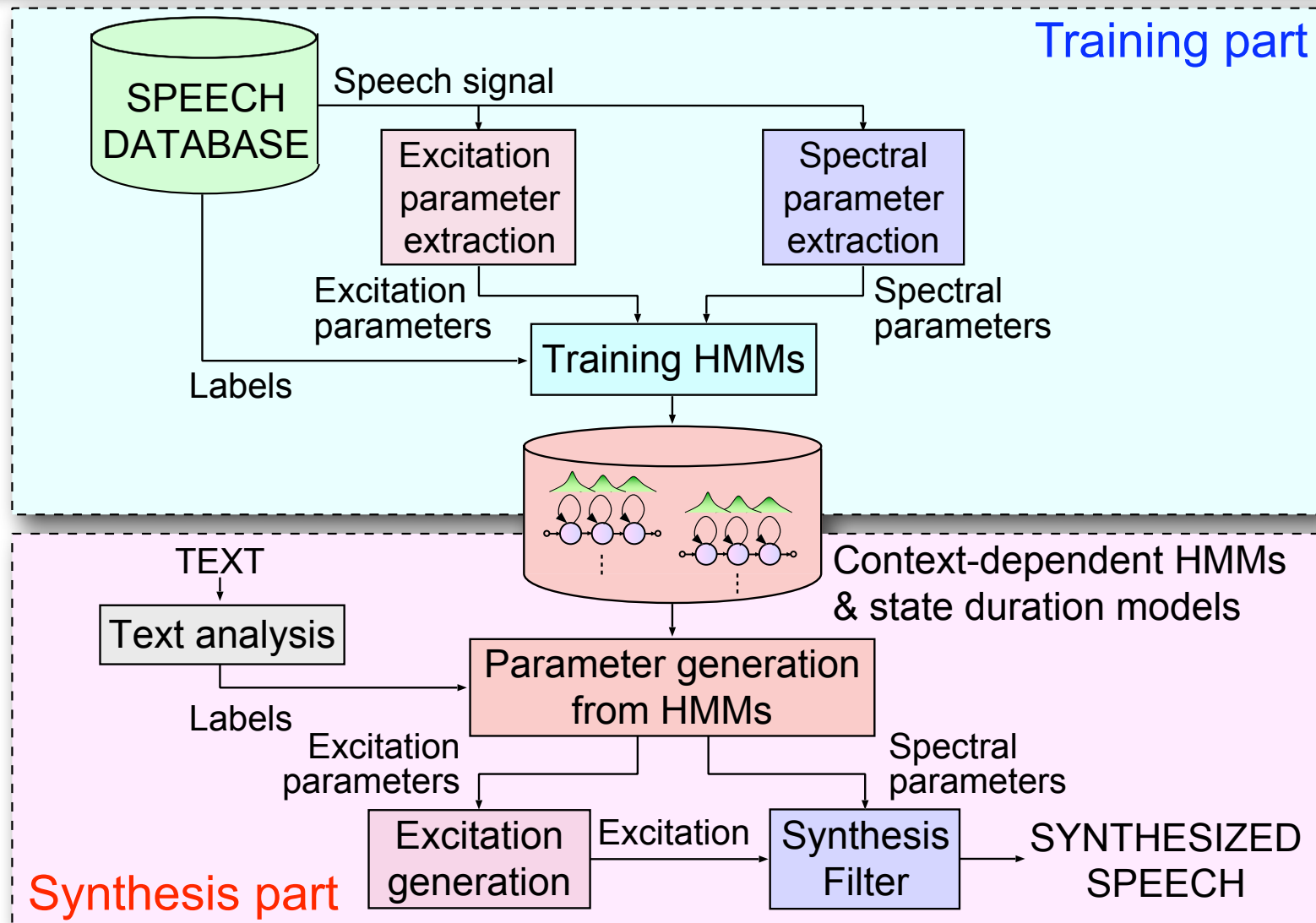



# Title of each lecture

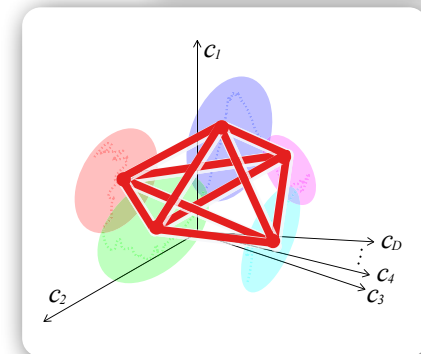

- Theme-1
  - ~~Multimedia information and humans~~
  - ~~Multimedia information and interaction between humans and machines~~
  - ~~Multimedia information used in expressive and emotional processing~~
  - ~~A wonder of sensation - synesthesia -~~
- Theme-2
  - Speech communication technology - articulatory & acoustic phonetics -
  - Speech communication technology - speech analysis -
  - Speech communication technology - speech recognition -
  - Speech communication technology - speech synthesis -
- Theme-3
  - A new framework for “human-like” speech machines #1
  - A new framework for “human-like” speech machines #2
  - A new framework for “human-like” speech machines #3
  - A new framework for “human-like” speech machines #4

# Assignment

---

- Assignment
  - Read a research paper which is related to the second four lectures of this class, **summarize it**, and **give your own comments** to the paper.
    - Phonetics, speech science, and speech technology
  - All the materials used in the lectures can be available at:
    - <http://www.gavo.t.u-tokyo.ac.jp/~mine/japanese/media2017/class.html>
- Length
  - A few pages of A4 size.
- Submission
  - Your report should be sent to [mine@gavo.t.u-tokyo.ac.jp](mailto:mine@gavo.t.u-tokyo.ac.jp) in the form of PDF.
  - **The file name should be “[student id]\_[your name].pdf”**
    - **36-302439\_nobuaki-minematsu.pdf**, for example.
  - The paper that you read should be attached.
- Deadline
  - 23:59:59 on Dec. 19th

